

TOTIMO

Curated Design Showroom

OBJEKTO

info@totimodesign.com / +30 210 361 17 32 / totimodesign.com
Voukourestiou 32 Kolonaki, Athens

#14

OBJEKTO



#14

OBJEKTO



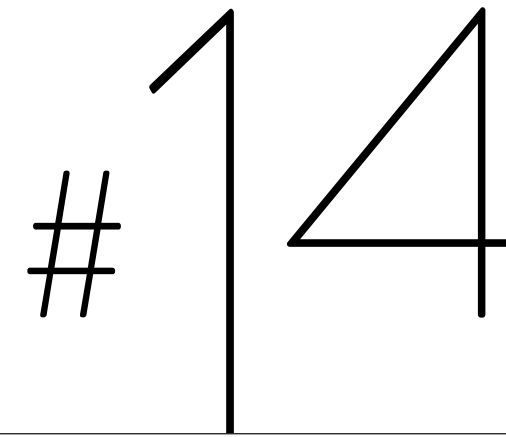

En marge des tendances, Objekto a toujours recherché des créations à forte identité, qui pour la plupart d'entre elles, ne sont pas l'œuvre de designers, mais plutôt d'architectes, ou encore d'ébénistes, d'artistes, de graphistes ou d'ingénieurs... Autant de créateurs qui adoptent un point de vue différent sur l'objet et l'envisagent sous l'angle de sa pérennité. Cette dimension patrimoniale conjugue poésie de la ligne, qualité d'usage et des matières, pour aboutir à la création d'archétypes intemporels : un universalisme inscrit dans le nom même d' « objekto », qui en esperanto signifie objet.

Objekto has created a collection of long-standing successes and bestsellers. Remaining on the sidelines of frenzied trends, the brand has always sought out creations with strong identities which, for the most part, are not the works of designers, but of architects, cabinetmakers, artists, graphic designers or engineers. Creative spirits with a different perspective on objects, who envision them with long life and lasting use in mind. This legacy-oriented approach combines the poetics of line with quality of use and materials, all consummated in the creation of timeless archetypes: a universalism found in the maker's very name, Objekto, meaning "object" in Esperanto.



OBJEKTO

FABRICANT EXCLUSIF MONDIAL DEPUIS 2004
DE CRÉATIONS INTÉMPORELLES DESSINÉES PAR DES
ARCHITECTES ET ARTISTES DE RENOM

ALLIANT **QUALITÉ, FONCTION ET CONFORT**

AVEC UNE **APPROCHE RESPONSABLE, DURABLE, ET**
À FAIBLE IMPACT ENVIRONNEMENTAL

ET DES MATIÈRES PREMIÈRES ET PRODUCTIONS
100% EUROPÉENNES

DROITS D'AUTEURS

En raison de leur valeur artistique et de leur caractère créatif singulier, tous les modèles édités par Objekto sont protégés par le droit d'auteur. La protection légale est assurée pendant toute la vie de l'auteur et 70 ans après son décès. Objekto est très impliqué aux côtés d'autres fabricants pour lutter contre la contrefaçon.

FOCUS SUR LES MATIÈRES PREMIÈRES

- **CUIR** : nous utilisons des cuirs français au tannage végétal pour leur qualité, leur beauté, leur résistance et leur rareté. Aucun produit chimique comme le chrome n'est utilisé dans le processus de tannage, mais des tanins naturels contenus dans des poudres d'écorces d'arbres, garantissant ainsi une production respectueuse de l'environnement. Nos cuirs sont pleine fleur, semi-aniline et sans correction de la surface pour éliminer les imperfections. Les marques naturelles éventuellement présentes sur le cuir sont le témoignage de la vie active de l'animal, une preuve d'authenticité qui confère au meuble un caractère unique. Des cuirs qui respirent et se patinent avec le temps.

- **ACIER** : Les aciers que nous utilisons sont recyclés à 90 % et produits sur demande. Notre partenaire sidérurgiste français d'acier est engagé dans un programme qui vise à créer la première « aciérie circulaire » au monde, positionnant ainsi cette industrie comme un acteur clé pour le recyclage des métaux stratégiques. Notre cahier des charges étant très spécifique en termes de résistance, d'élasticité, de mémoire de forme et de diamètre, les aciéries produisent nos propres coulées d'acier, ce qui est extrêmement rare.

- **BOIS** : tous les bois que nous utilisons sont issus de forêts européennes exploitées de manière durable. Le chêne et le noyer proviennent d'Europe centrale et le hêtre d'Italie. Le contreplaqué que nous utilisons est certifié CARB garantissant notamment l'absence de bisphénol.

- **VERRE** : Produit en Italie par une verrerie familiale qui utilise des sables premium pour fabriquer des verres trempés de haute qualité.

- **MARBRE** : nous travaillons avec une petite marbrerie artisanale localisée près de Carrare, et une carrière confidentielle qui sélectionne et extrait les plus beaux blocs de marbre Bianco Fiorito, très recherché pour sa blancheur et son veinage fleuri. Ces blocs sont réservés et stockés, nous garantissant d'avoir toujours la meilleure qualité.

- **TISSU** : Nous avons choisi les tissus Sunbrella® de la gamme Heritage en raison de leur très bonne résistance en extérieur, mais surtout car ils sont fabriqués à partir de fibres recyclées, ce qui reste très rare pour des tissus.

A **WORLDWIDE EXCLUSIVE MANUFACTURER SINCE 2004**
OF **TIMELESS DESIGNS** CREATED BY RENOWNED
ARCHITECTS AND ARTISTS

FOCUSING ON **QUALITY, FUNCTION AND CONFORT**

WITH A **RESPONSIBLE, SUSTAINABLE AND LOW**
ENVIRONMENTAL IMPACT APPROACH

AND A **100% EUROPEAN RAW MATERIALS AND**
PRODUCTIONS

COPYRIGHTS

Because of their artistic value and their particular and single creative nature, all creations of the Objekto's collection are protected by copyrights. Legal copyrights protection is ensured during all the life of the author and 70 years after its death. Objekto is very involved in the fight against copies in partnership with other manufacturers.

FOCUS ON MATERIALS

- **LEATHER** : we use French vegetanned leathers for their quality, beauty, durability and rarity. No chemicals like chrome are used for the tanning process but natural tannins contained in tree powders, ensuring thereby an eco-friendly production. Our leathers are full grain, semi-aniline with no surface correction to remove imperfections. Natural marks that may be present are the hallmarks of the animal's active life, a proof authenticity and give the piece of furniture a unique sens of character. Leathers that breath and get patina with years.

- **STEEL** : all the steel we use is 90% recycled and produced on demand. Our French stainless steel producer is involved in a program that aims to create the world's first « circular steel plant », positioning the steel industry as a key player in the recycling of strategic metals. As our specifications are unique in term of resistance, flexibility, memory shape and diameter, steel factories produce our own steel castings, which is extremely rare.

- **WOOD** : all the woods come from sustainably exploited European forests. Oak and walnut come from Central Europe and beech from Italy. The plywood we use is CARB certified ensuring in particular the absence of bisphenol.

- **GLASS** : Produced in Italy by a family-owned glass factory that use premium sand to make high quality tempered glasses.

- **MARBLE** : we work with a small artisanal marble factory near Carrara that sourced for us an exclusive quarry which selects and extracts the most beautiful blocks of Bianco Fiorito marble, highly sought after for its whiteness and flowery veining. These blocks are stored ensuring that we always have the best quality.

- **FABRIC** : We chose Sunbrella® fabrics from the Heritage range because of their excellent outdoor resistance, but above all because they are made from recycled fibres, which is very rare for fabrics.



Paulo Mendes da Rocha



Reno Bonzon



Flavio de Carvalho



Fernando Jaeger



Mauricio Klabin



Fournier + Endrizzi



Ilse Lang



Michel Arnout



Rafic Farah



Pierre Gonalons



Magnus Long



Giulio Lazotti



Pedro Paulo Venzon



117201756

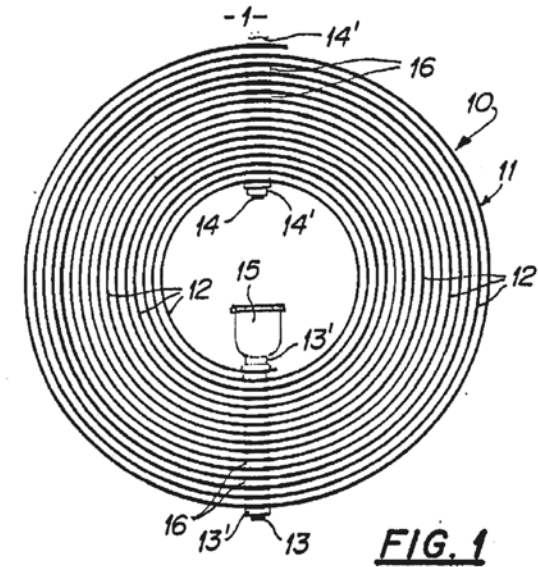

FIG. 1

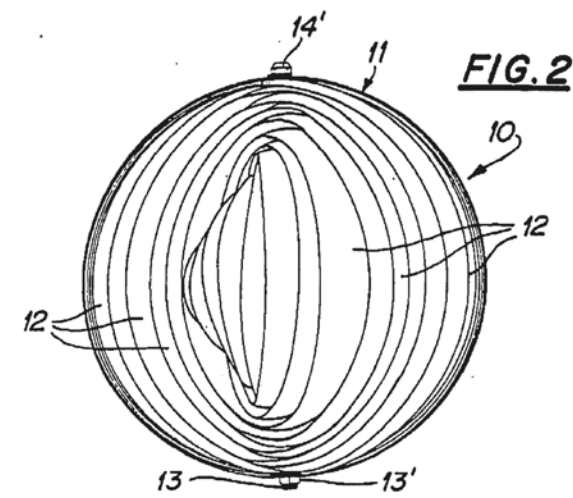

FIG. 2

« Je pense que le travail d'un designer doit être de bonne qualité, beau et bon marché. Avec la lampe Eclipse j'ai surmonté le trauma du design cher. J'ai besoin qu'existent des objets populaires. » Mauricio Klabin.

Depuis 2006 la lampe Eclipse fait partie de la collection permanente du Musée d'Art Moderne de New York (MoMA).

"I believe that the work of a designer must be good quality, beautiful and affordable. With the Eclipse lamp I overcame the trauma of expensive design. I want design pieces to be popular." Mauricio Klabin.

Since 2006 the Eclipse lamp has been part of the permanent collection of the Museum of Modern Art of New York (MoMA).





L'une des principales préoccupations de Mauricio Klabin est d'inspirer une sensation de bien-être et de protection. Ses créations contiennent et enveloppent. La lampe Eclipse est une illustration parfaite de sa conception du design.

One of the main concerns of Mauricio Klabin was to inspire a feeling of wellbeing and protection. His works contain and cocoon. The Eclipse lamp is a perfect example of his conception of design.









Paulo Mendes da Rocha est une légende de l'architecture contemporaine. Son travail est assimilé à «l'école d'architecture brutaliste de São Paulo». Un brutalisme qui se réfère au béton brut, aux formes simples. Il crée des œuvres à la fois sincères et audacieuses, imaginatives et inattendues, et laisse toujours une place importante à la dimension sociale dans son art.

L'architecte est un homme qui porte un intérêt sincère à l'humanité. Sa mission est de créer l'habitat le plus adéquat et le plus durable possible. En ce sens, Paulo Mendes da Rocha est un moderniste, rien ne le distrait de sa vision d'un avenir meilleur.

Récompensé à de nombreuses reprises, il a notamment reçu le Prix Pritzker en 2006 et le Lion d'Or de la Biennale de Venise en 2016.

Paulo Mendes da Rocha is a legend in contemporary architecture. His work is related to the "São Paulo brutalist school of architecture". Brutalism that refers to raw concrete, to simple shapes. He creates works that are both sincere and daring, imaginative and unexpected. He always gives the social dimension an important place in his art.

An architect is someone who is particularly interested in humankind. The main goal of an architect is to create the most adequate and sustainable habitat possible. Paulo Mendes da Rocha is a modernist. Nothing distracts him from his vision for a better future.

Among other awards, he was honored by the Pritzker Prize in 2006 and the Venice Biennale Golden Lion in 2016.



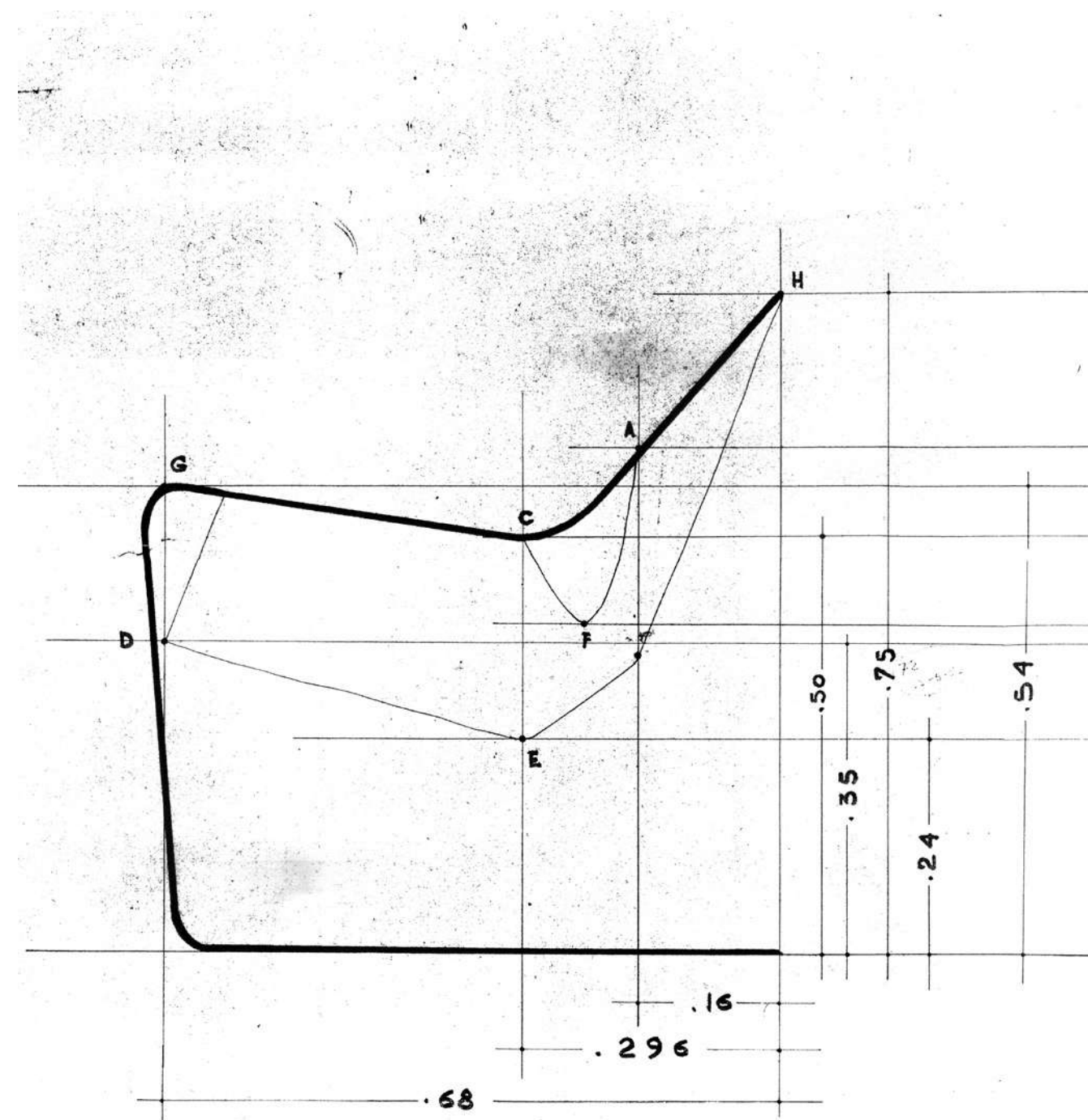
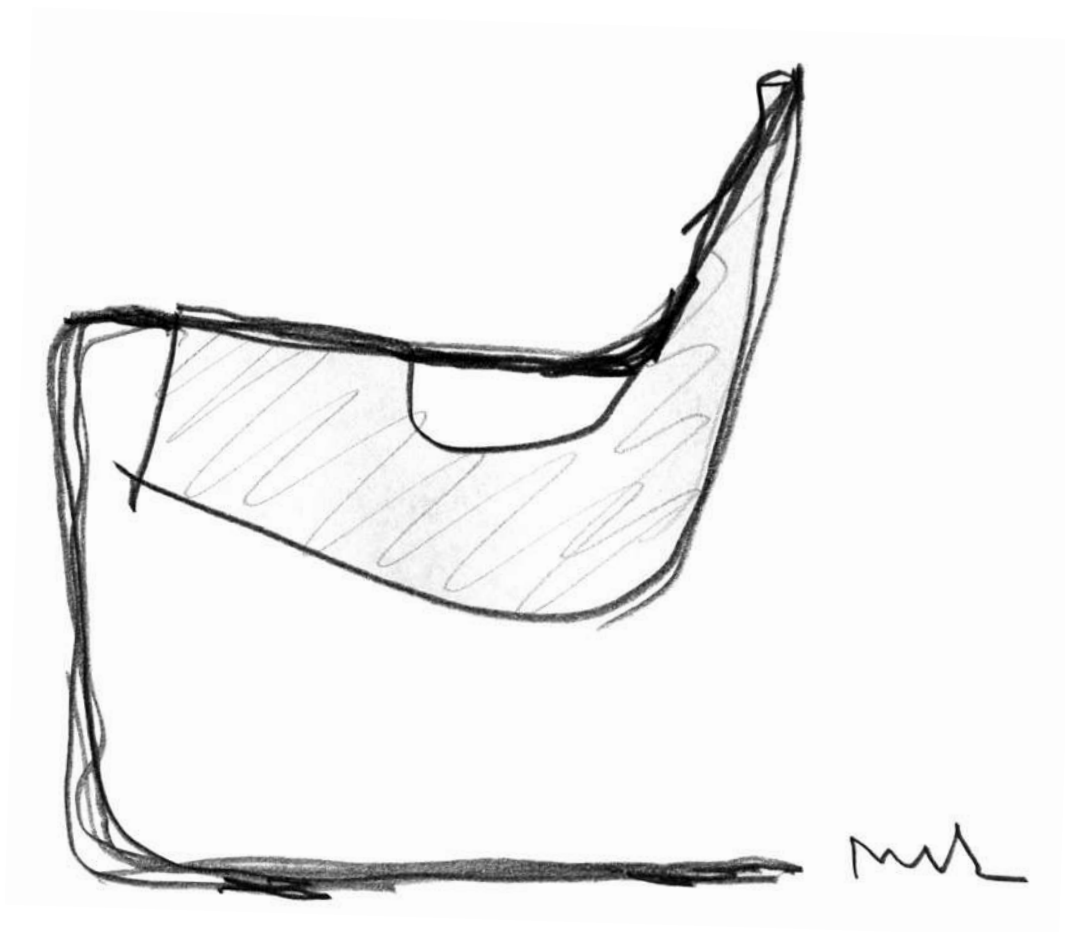

CADEIRA 'PAULISTANO'
DIREITOS RESERVADOS
ESCALA 1:4
M. S. 85 / 7

Un fauteuil culte signé de la main de Paulo Mendes da Rocha, lauréat 2006 du prix Pritzker d'architecture. Très confortable, le Paulistano est un classique du design à l'élégance intemporelle. Il fait partie de la collection permanente du Musée d'art Moderne de New York (MoMA) depuis 2007.

A must-have lounge chair designed by Paulo Mendes da Rocha, winner of the 2006 Pritzker Prize. Very comfortable, the Paulistano lounge chair is a classic piece in timeless chic design. It has been part of the permanent collection of the Museum of Modern Art of New York (MoMA) since 2007.





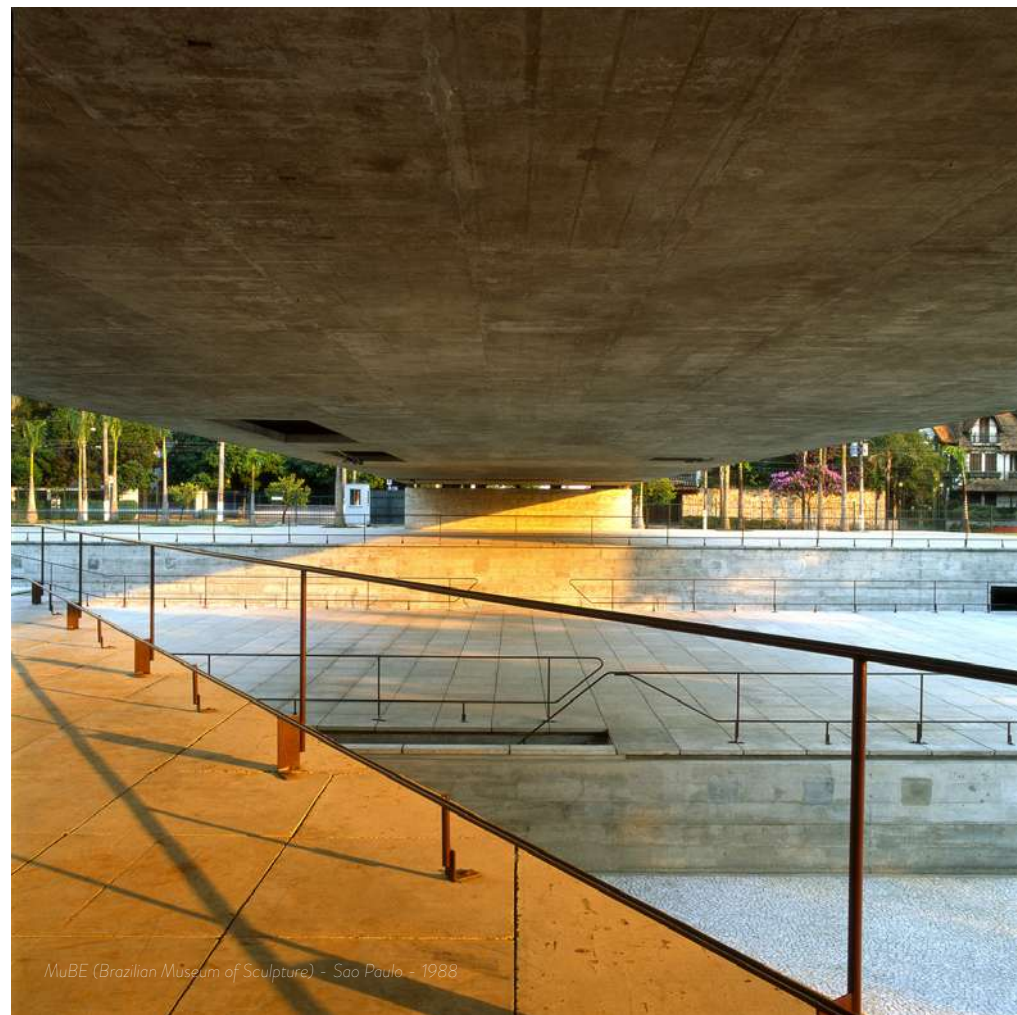
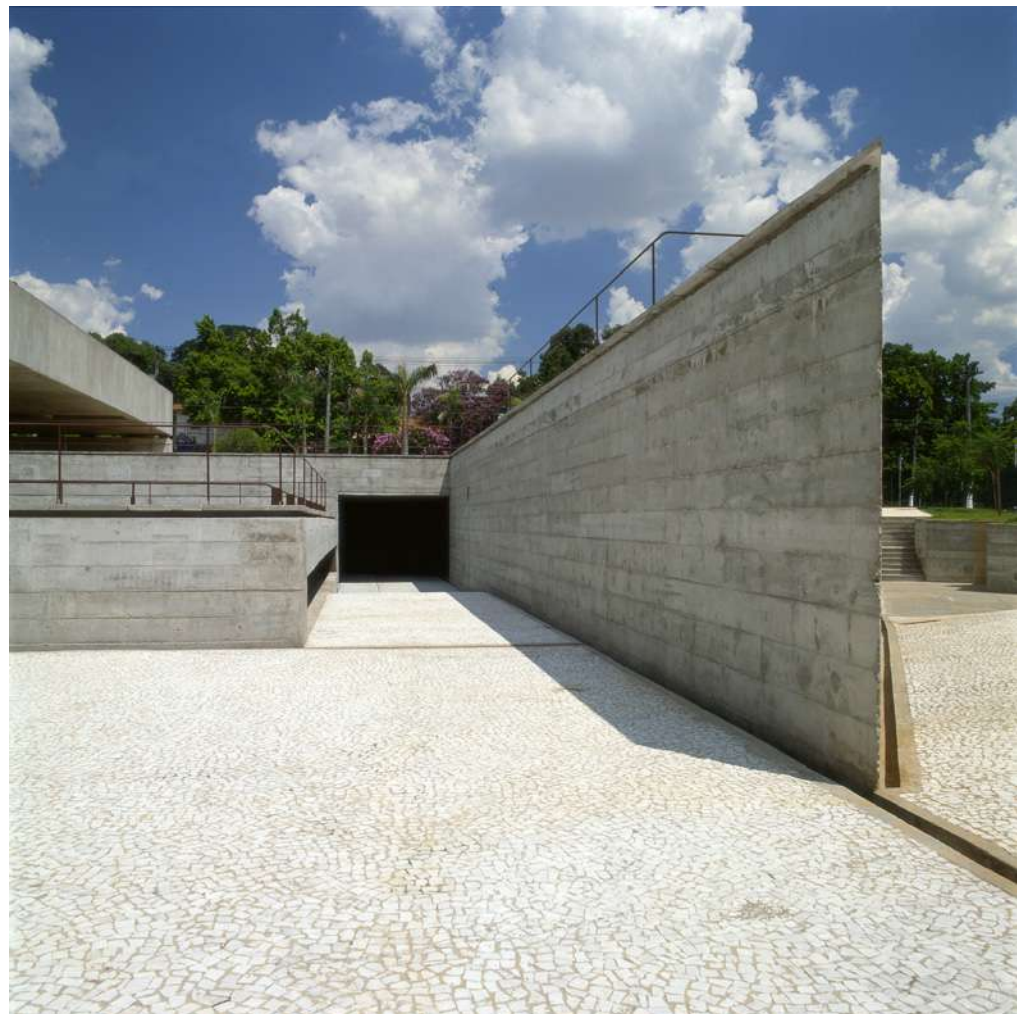

MuBE (Brazilian Museum of Sculpture) - Sao Paulo - 1988



PAULISTANO
ARMCHAIR
MESH

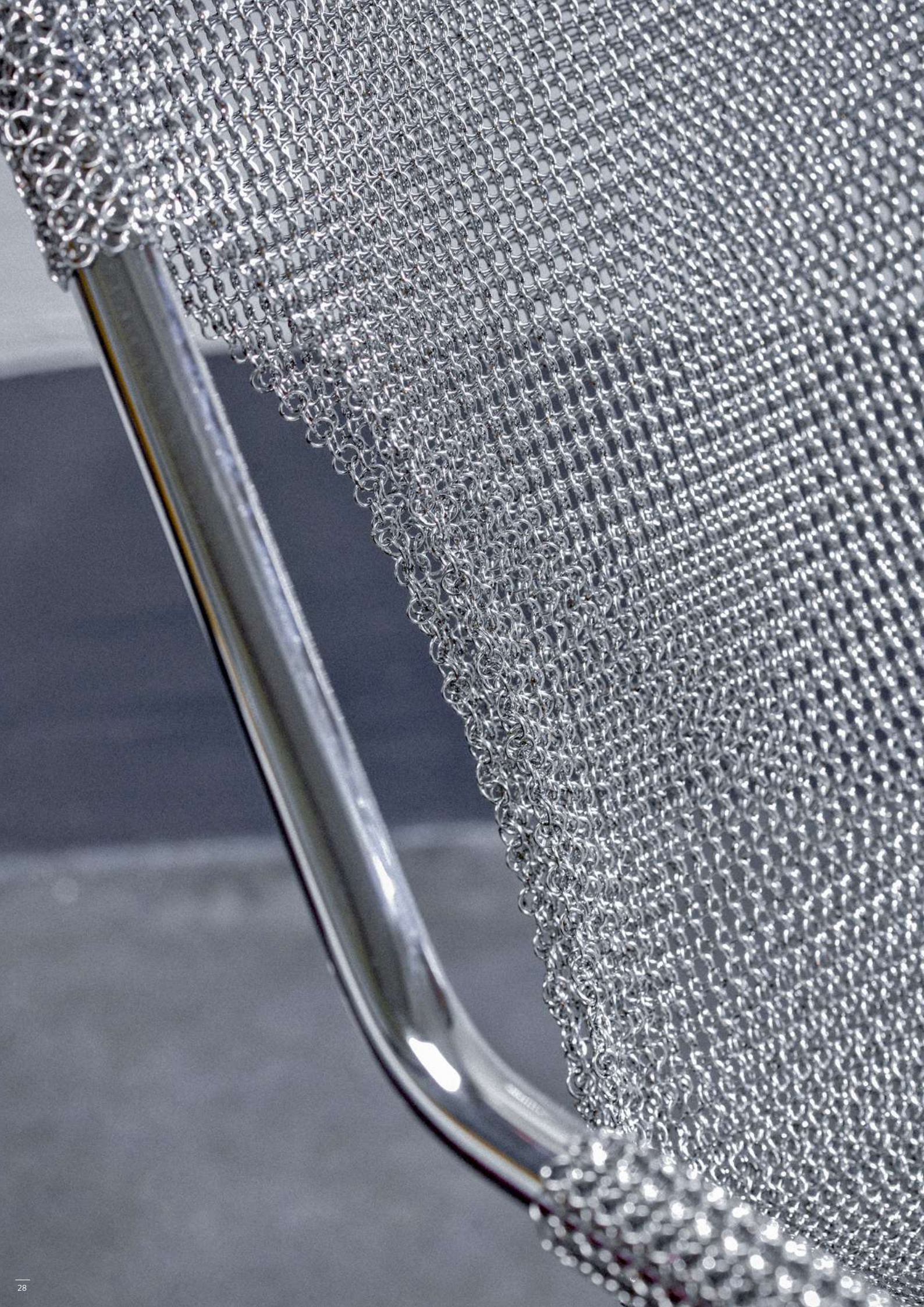

Le Paulistano, classique et intemporel, dans sa version outdoor pour l'été qui rejoint le salon en hiver.

The timeless classic Paulistano chair in outdoor version. From outdoor in summer to the living room in winter.





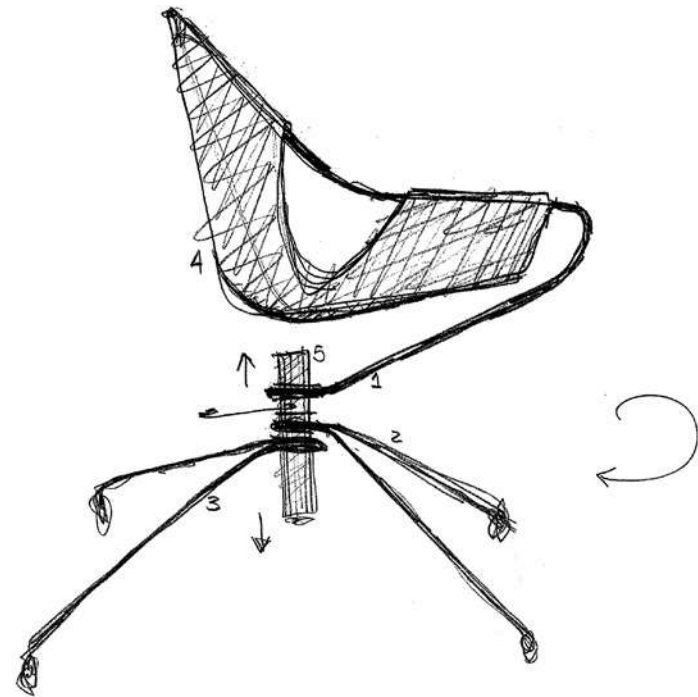

com projeto industrial esse protótipo usa, nitidamente, virtudes de materiais e produtos do mercado. Principalmente a flexibilidade do aço, barras maciças de seções circular produzida em grande parte, para a construção de molas espirais. Rodízios de apoio. Cilindro de giracões no plano horizontal e regulagem de altura, a gás. Tecidos ou couro. É uma "montagem" simples destes materiais. As três peças de aço flexível, ajustam-se como "aduelas" ao cilindro padrão, adaptado. O assento é "vestido" na estrutura. Desenhado para "Nucleon" em 1985



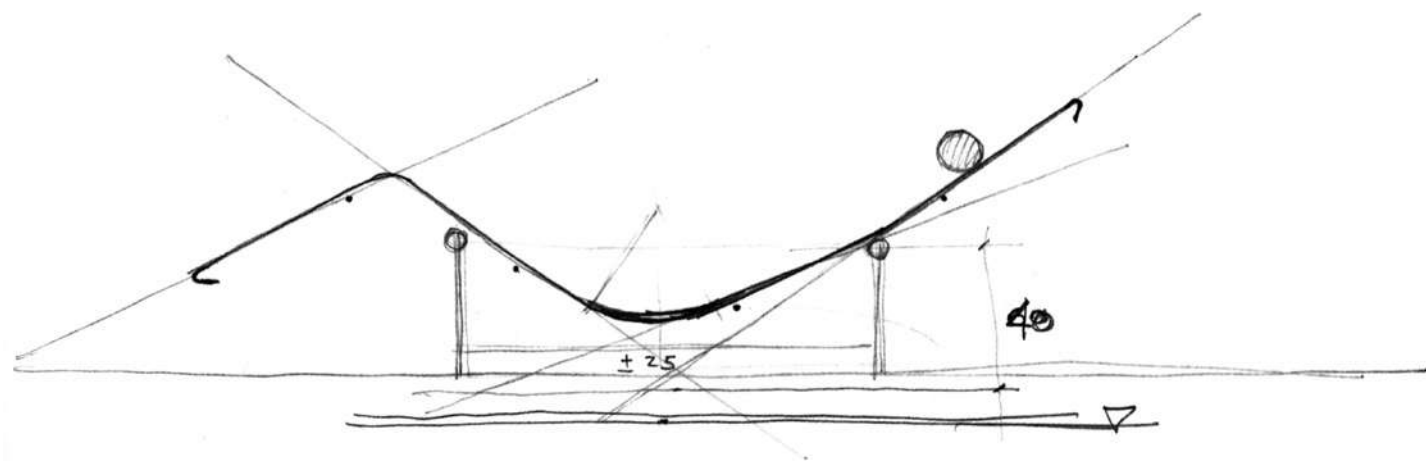

« Au milieu des années 80 je me suis rendu dans une immense usine de ressorts. Là, j'ai vu des bobines d'acier d'une largeur de 25 cm, minces comme du papier. J'ai immédiatement pensé à l'idée d'un corps humain allongé comme flottant au dessus du sol sur cette fragile feuille flexible » Paulo Mendes da Rocha.

"In the middle of the 80s I visited a huge spring factory. There I saw 25cm-wide steel coils as thin as a sheet of paper. I immediately thought of the idea of a human body stretched out on this thin flexible sheet like floating over the ground." Paulo Mendes da Rocha.





L'une des plus belles créations de Michel Arnout est sûrement le Peglev littéralement « je prends et j'emporte ». Cet émigré Français au Brésil, est considéré comme le père des meubles démontables qu'il commença à dessiner au début des années 50. Il a toujours ardemment défendu la démocratisation du design au détriment de toute vanité créative.

The masterpiece of Michel Arnout is the Peglev, literally "I take and I carry". This Paris-born adoptive Brazilian, known as the pioneer of "ready-to-assemble" furniture, started designing furniture in the early 50s. He ardently defended the democratization of design at the expense of any creative vanity.







Les courbes du rocking-chair Gaivota furent définies alors que Reno Bonzon séjournait dans les Alpes. Surpris par l'empreinte laissée par son corps dans la neige après y avoir été assis, et dans un souci d'ergonomie, il chercha alors à reproduire cette forme.

The curved forms of the Gaivota rocking chair were defined by Reno Bonzon, as he was sat in deep snow during a stay in the Alps and had a look at his bodyprint after standing up. Keeping ergonomics in mind, Reno wanted to reproduce this comfortable shape.



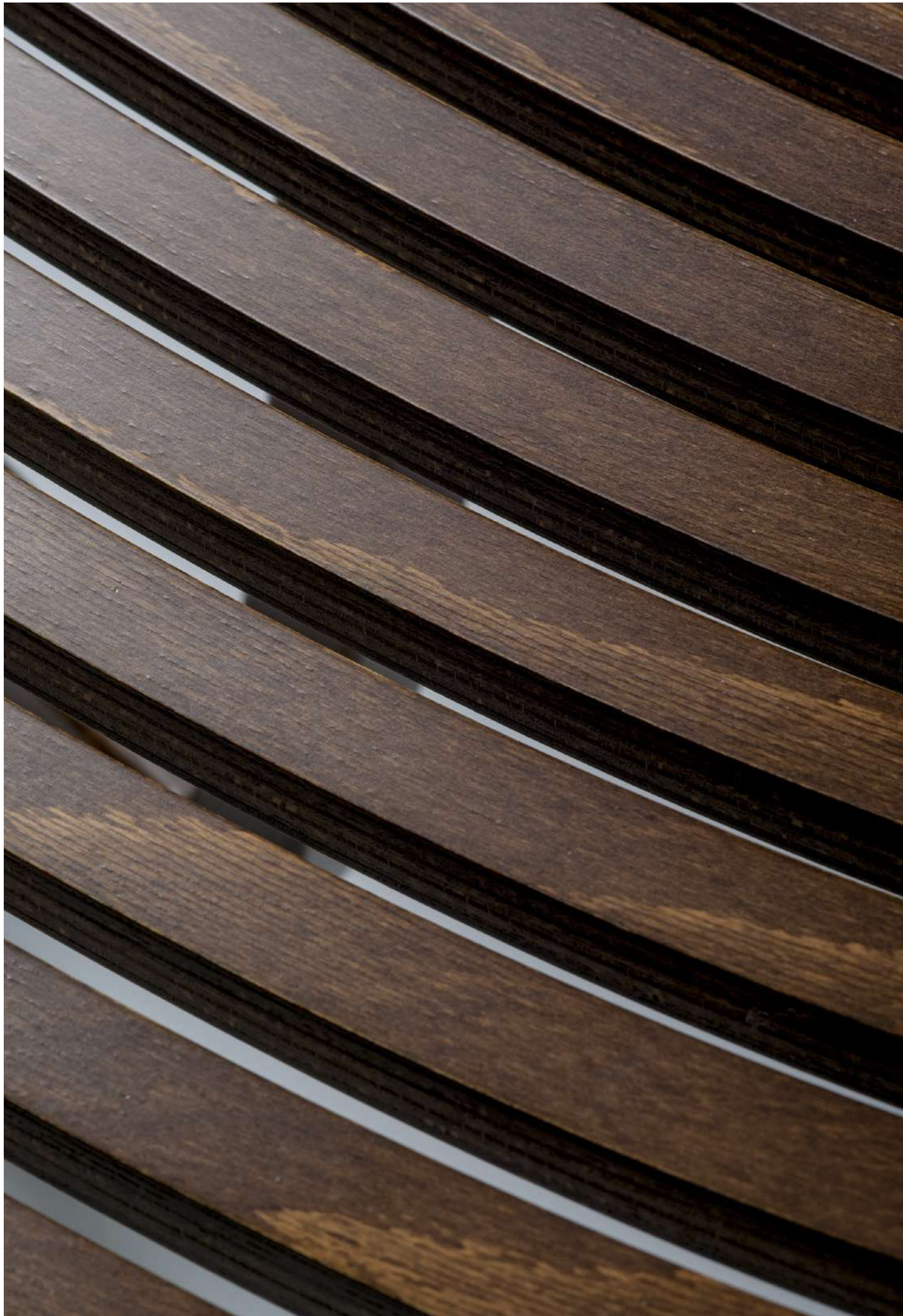

GAIVOTA ROCKING CHAIR



Le travail de Reno Bonzon est largement basé sur l'utilisation du bois, et en particulier sur la technique du lamellé-collé dont il est l'un des précurseurs au Brésil. Cette technique de fabrication confère à ses créations, comme le rocking chair Gaivota et le lampadaire Nuala, légèreté et élégance.

The work of Reno Bonzon is mainly based on woodcraft, and more precisely on the technique of laminated wood which he is one of the pioneers in Brazil. This technique gives his pieces, such as the Gaivota rocking chair and the Nuala floor lamp, lightness and refinement.





Un point remarquable de la Gabi de Reno Bonzon est qu'elle est constituée de deux pièces uniquement : côtés et traverses. Contrairement à beaucoup de chaises, les traverses constituent l'assise et le dossier, structurant l'ensemble. Le triangle formé par la jonction des trois bandes latérales de lamellé-collé donne élégance et caractère à cette chaise de « bistrot » légère, empilable et très résistante.

A key feature of the Reno Bonzon's Gabi is to combine only two parts: sides and crosspieces. Unlike many chairs, these crosspieces themselves constitute both seat and back and structure the whole frame. The triangle formed by the junction of the three plywood side stripes gives elegance and character to this light, stackable and very resistant "bistrot" chair.





Le tabouret Bienal offre une large assise incurvée et rembourrée pour un confort parfait et durable. Le Bienal est adapté à une utilisation résidentielle ou commerciale, en tabouret de bar ou de comptoir.

These bar and counter-height stools bring a satisfying curve to a wide seat that generously padded for lasting comfort. The Bienal stool is suitable for residential and commercial use.





Fernando Jaeger est l'un des principaux acteurs du design brésilien et sûrement, avec plus de 200 créations, l'un des designers les plus productifs. Son but est de montrer qu'il est possible de créer de beaux produits, accessibles et qui, en plus d'être intelligents et de remplir leur fonction, ont une forte identité brésilienne.

Fernando Jaeger is one of the Brazilian design key players and surely, with more than 200 creations, one of the most productive designers. Its purpose is to show that it is possible to create beautiful products, accessible and which, in addition of being smart and fulfill their function, have a strong Brazilian identity.

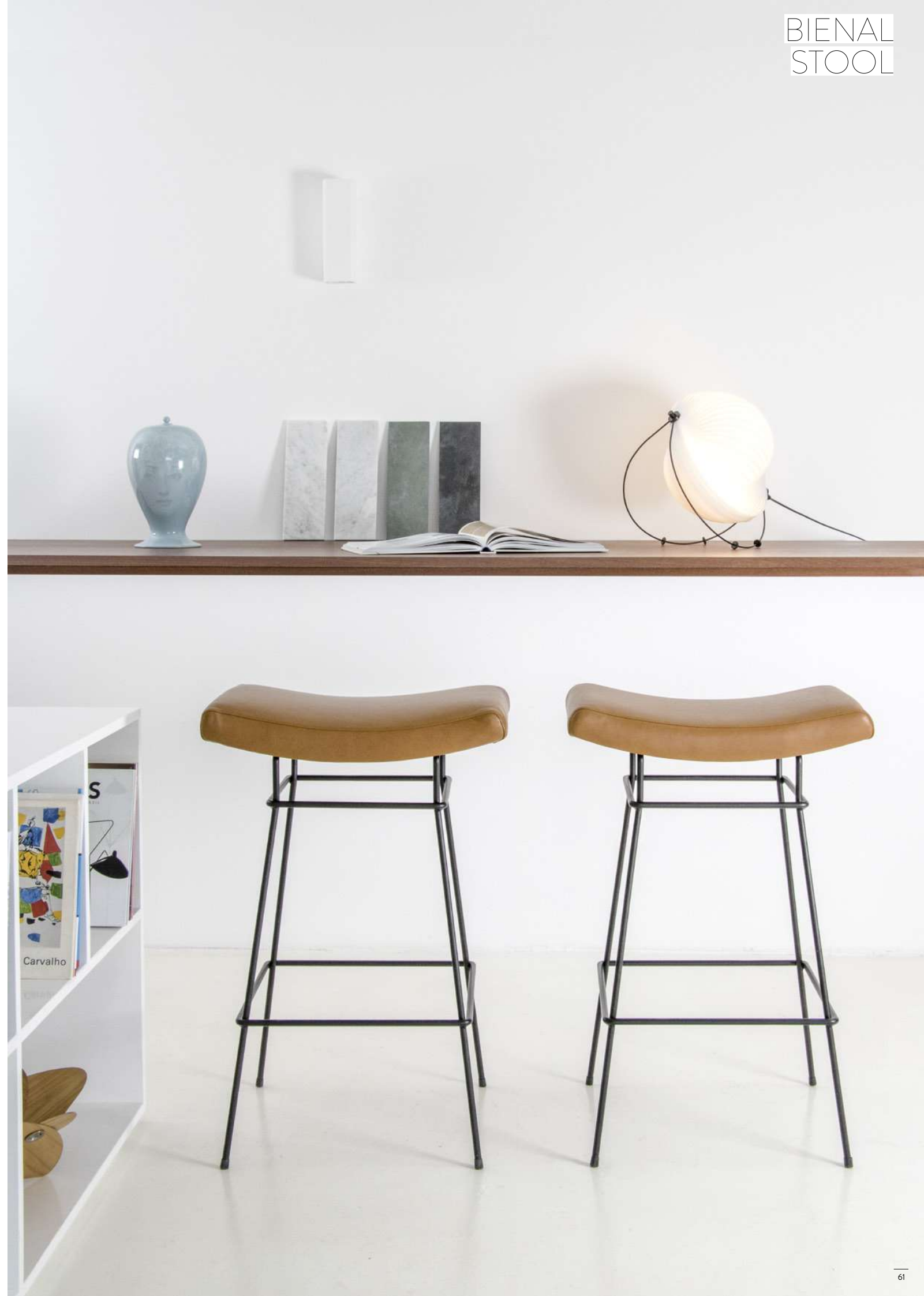



En créant les Tribo, Ilse Lang s'est inspirée des tabourets traditionnels en bois utilisés par les cowboys du sud du Brésil, les gauchos, lorsqu'ils se réunissaient le soir autour du feu pour partager un maté.

To design the Tribo line, Ilse Lang was inspired by the traditional wooden stools used by the "gauchos" - southern Brazilian cowboys - as they gathered around campfires drinking mate.





Selon Ilse Lang, l'innovation est de rendre les choses plus simples encore qu'elles ne le sont déjà. Elle considère la simplification comme une évolution : se concentrer sur l'essentiel. Un bon design ne peut être réduit à un simple aspect visuel ou à une pure innovation technologique. Un bon design est un équilibre entre la forme et la fonction.

According to Ilse Lang, innovation means making things even simpler than they already are. She considers simplification to be an evolution: to focus on what is essential. Successful design cannot be reduced to a mere visual aspect or to a pure technical innovation. Successful design is a balance between shape and function.



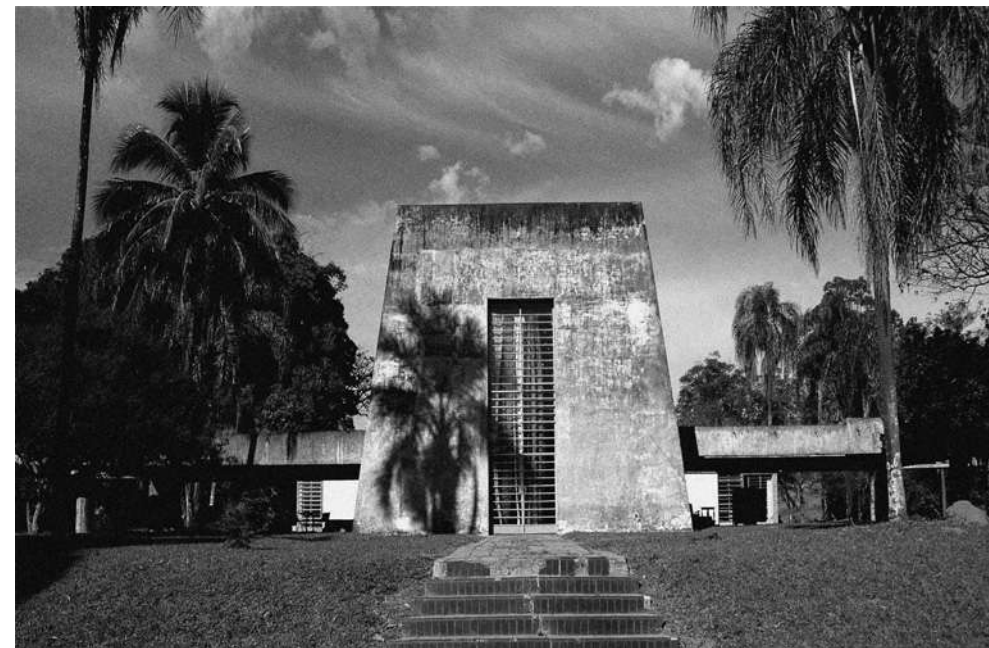

Flavio de Carvalho - Fazenda Capuava - Valinhos (Sao Paulo) - circa 1930



Le fauteuil FDC1 est une pièce rare et unique. Dessiné dans les années 50 par l'artiste Flávio de Carvalho, ce fauteuil très graphique, presque tribal, est reconnu aujourd'hui comme l'un des plus beaux héritages de cet artiste que Le Corbusier qualifiait de « révolutionnaire romantique ».

The FDC1 armchair is an exclusive and rare piece of furniture designed by artist Flávio de Carvalho in the 50s. This sculptural tribal lounge chair is one of designer's masterpieces, deemed by Le Corbusier as a "romantic revolutionary".





Pedro Paulo Venzon est un jeune et prometteur designer dont le travail très singulier autour du design moderne brésilien a été récompensé à de nombreuses reprises dans son pays d'origine ainsi qu'à l'international. La table d'appoint Moça est sa première création à être éditée. Elle combine la rigidité de l'acier et la légèreté de cette silhouette changeante faite de courbes simples et féminines.

Pedro Paulo Venzon is a young and promising designer whose singular work around Brazilian modern design has been awarded many times in Brazil and abroad. The Moça side table is his first creation to be licensed. It combines the rigidity of steel and the lightness of this changing silhouette made of simple and feminine curves.









Raphael Fournier est un architecte et designer français, installé à Barcelone. Martin Endrizzi est un designer industriel argentin, installé à Mendoza. Ensemble, ils développent des projets dans les domaines du mobilier, design d'objets, direction créative, design d'intérieurs et scénographies. Tipi est le premier fruit de leur collaboration.

Raphael Fournier is a French architect and designer based in Barcelona. Martin Endrizzi is an Argentinian industrial designer based in Mendoza. They develop together projects in the fields of furniture and object design, creative direction, interior design and scenography. Tipi is the first result of their promising collaboration.

Tipi est une table nomade, ludique et pratique. Sa légèreté et sa large poignée permettent de la déplacer partout et d'accompagner la vie quotidienne. Comme table de nuit, table d'appoint à côté d'un canapé ou sur une terrasse, Tipi est parfaitement adaptée à une utilisation résidentielle ou en lieux publics.

Tipi is a nomadic side table, playful and precise. Its lightness and comfortable handle allow you to bring it along your daily moves. As a bedside table, an accent table, nearby a sofa or on a terrace, Tipi suits well in private homes as well as more public spaces. Tipi is concretely useful.







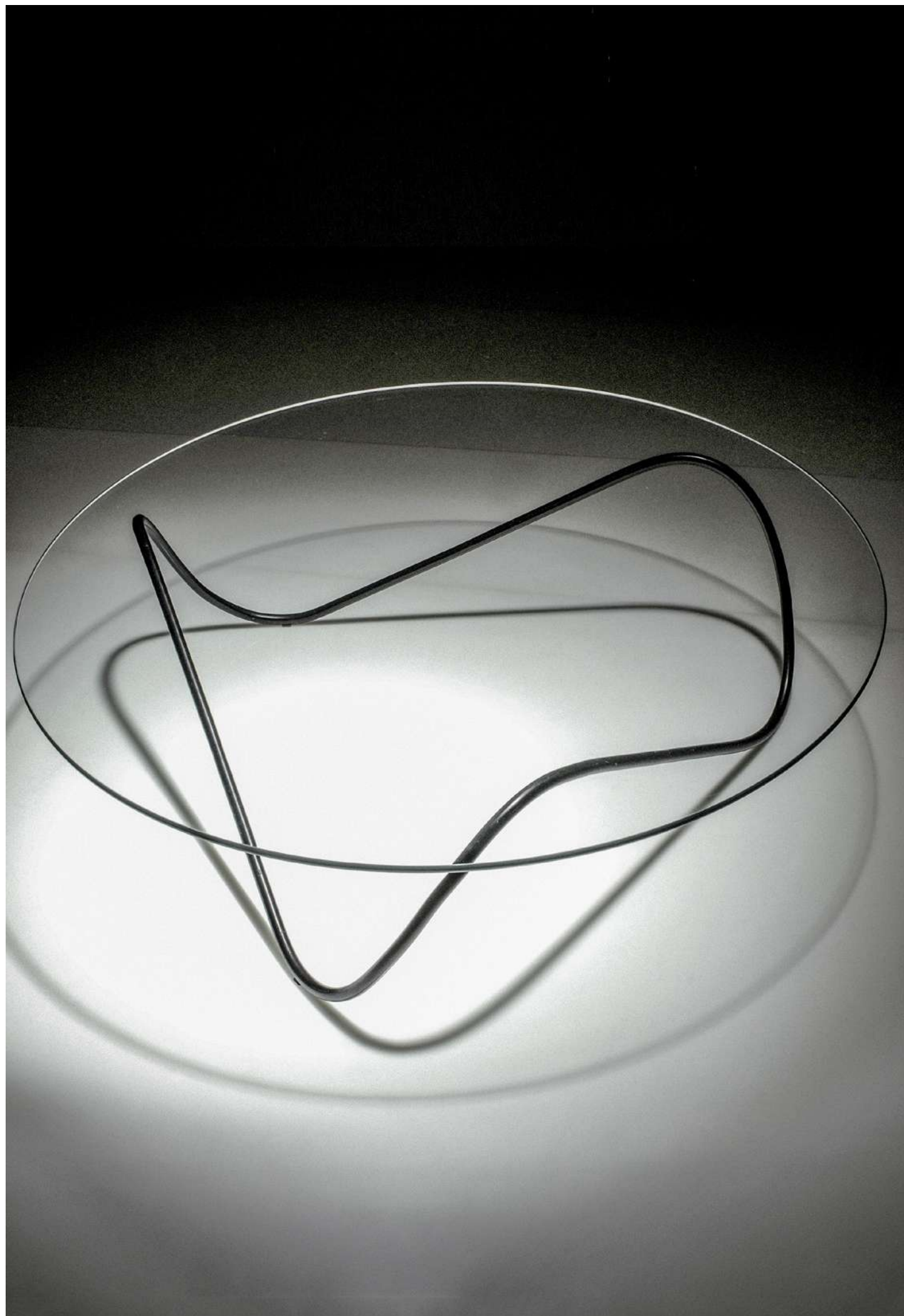

«Un jour, on a demandé à mon père : - En fait, Jorge, que fait ton fils ? Il réfléchit un instant et dit : - Il fait des petits boulots ici et là» Rafic Farah est un artiste polyvalent. Designer, architecte, directeur artistique, graphiste, photographe, scénariste. Un touche-à-tout qui dit de lui-même qu'il fut particulièrement influencé par les artistes méditerranéens et qu'il a choisi le design par hasard.

“One day, somebody asked my father: - By the way, Jorge, what does your son do? He thought about it for a moment, and said: - He does odd jobs here and there”. Rafic Farah is a versatile artist. A designer, architect, artistic director, graphic designer, and photographer. A man with many skills who says about himself that he was particularly influenced by Mediterranean artists and that he chose design by chance.

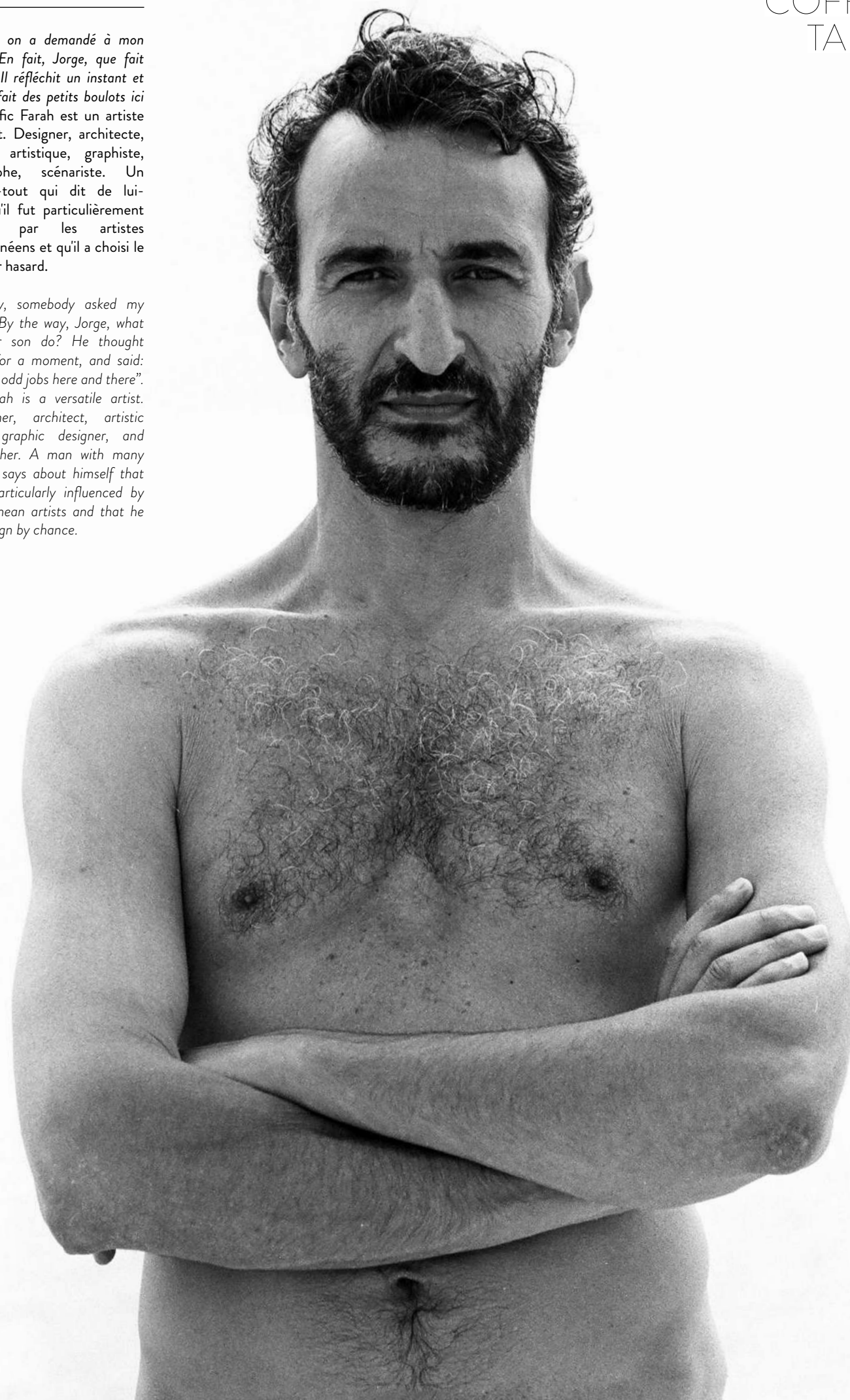



La table Kaeko du designer graphique et architecte brésilien Rafic Farah est une pièce d'exception à la fois simple et sophistiquée. Sa fascination et son admiration pour le Féminin lui ont inspiré cette table aux ondulations élégantes et sensuelles.

The Kaeko coffee table, designed by Brazilian graphic designer and architect Rafic Farah, is a simple yet sophisticated piece. Inspired by his fascination for women, Farah gave his Kaeko table stylish and sensual wavy lines.





MOEBIUS ACCENT TABLE



La table Moebius est un classique. La simplicité de ses lignes n'enlève rien au côté intrigant et complexe de cet assemblage de 3 pièces, et nous renvoie au ruban créé en 1858 par le célèbre mathématicien allemand August Ferdinand Moebius.

The Moebius accent table is a classic. The simplicity of the lines in no way lessens the intriguing and sophisticated character of this 3-pieces frame, referring us directly to the ribbon designed in 1858 by renowned German mathematician August Ferdinand Moebius



MOEBIUS
ACCENT
TABLE

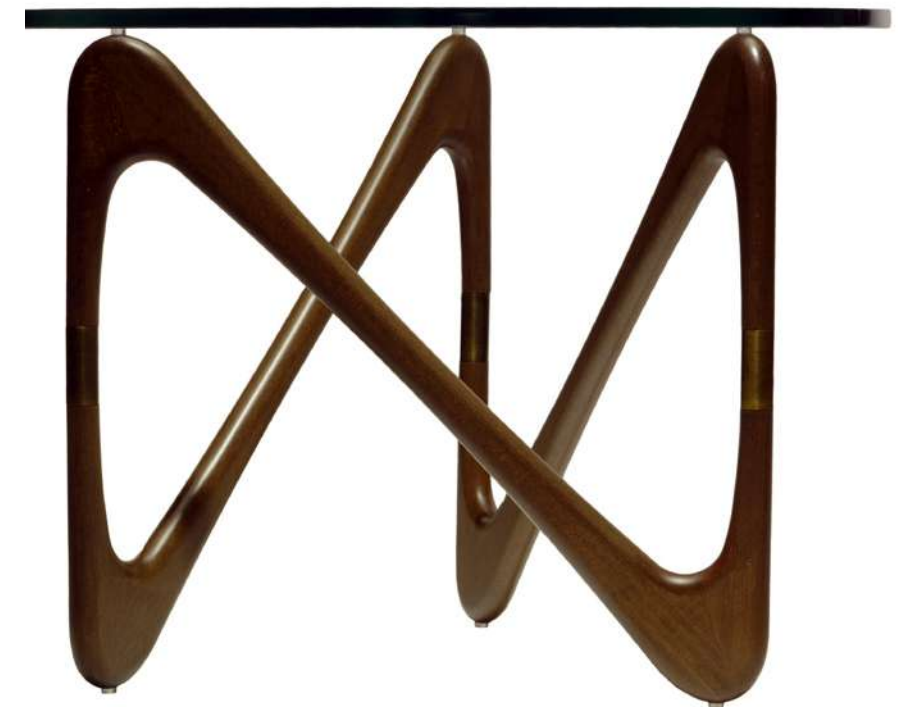

C'est en s'inspirant du livre « Il gioco dei quattro cantoni », écrit par Gianni Rodari et illustré par Bruno Munari, que Giulio Lazzotti a créé cette table basse. "Quattro Cantoni" fait référence au jeu traditionnel pour enfants qui consiste pour cinq participants à courir d'un coin à l'autre d'un carré sans perdre sa place. Le plateau de marbre est leur terrain ; les 4 pieds sont les enfants qui jouent, ou ces arbres qui courent dans le conte de Rodari.

Inspired by the book "Il gioco dei quattro cantoni", written by Gianni Rodari and illustrated by Bruno Munari, Giulio Lazzotti created this coffee table. "Quattro Cantoni" refers to the traditional children's game that involves five participants running from one corner to the other of a square without losing their place. The marble top is their land, the four feet are the children playing, or those running trees in Rodari's tale.



QUATTRO CANTONI
COFFEE
TABLE

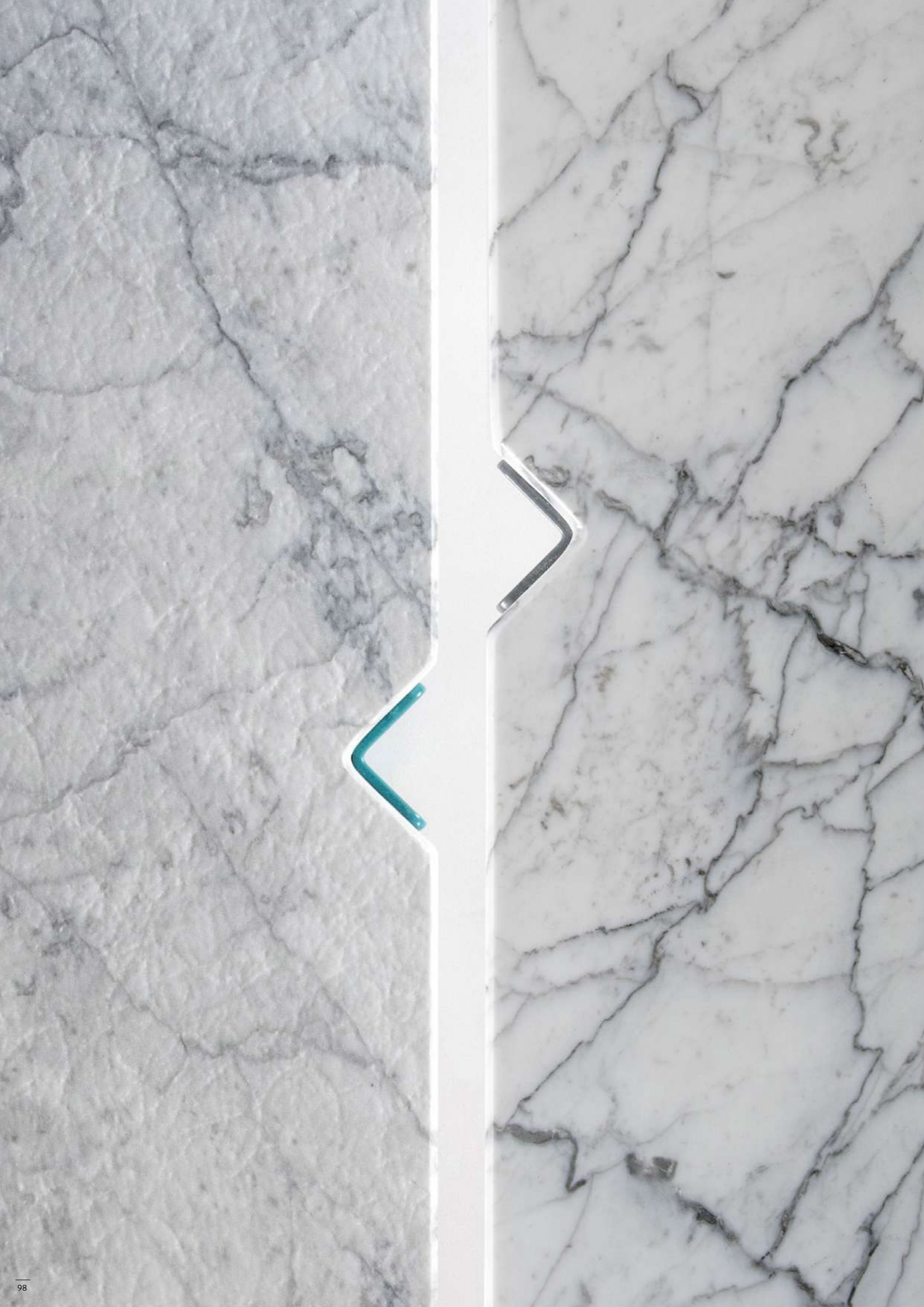



Giulio Lazzotti est un designer et architecte italien qui a toujours accordé une place importante à la dimension sculpturale des objets. Grand amoureux du marbre, son travail est moderne, conciliant un sens de l'artisanat et de la production industrielle. Souvent sollicité en tant que consultant pour son expérience, Giulio transmet à travers le monde son soucis du détail et collabore avec de grandes maisons d'éditions.

Giulio Lazzotti is an Italian designer and architect who has always given an important place to objects's sculptural dimension. A great lover of marble, his work is modern, reconciling a sense of craftsmanship with industrial production. Often hired as a consultant for his experience, Giulio shares his attention to detail throughout the world and collaborates with major furniture brands.



Créé par Pierre Gonalons, Photo est un abat-jour inspiré des éclairages techniques des plateaux de tournage ou des studios photo, un hommage aux films noirs des années 40.

Designed by Pierre Gonalons, the Photo lampshade is inspired by film production or photography studio lighting. A tribute to the 40s "film noir".

PAULISTANO

p.12, 18, 19, 20, 21, 22, 23, 24, 27, 71, 80, 87, 97, 102



- Barre acier carbone phosphaté / acier inoxydable poli / acier peinture époxy ø 19 mm
- Cuir pleine fleur - tannage végétal - semi-aniline
- Tissu 100% coton imputrescible, imperméable, anti-tâche

- Phosphated carbon steel / polished stainless steel / powder coated steel - solid bar ø 0.75"
- Full grain leather - vegetable tanned - semi-aniline
- Waterproof, rot proof and stain-proof 100% cotton canvas

Structure / Frame



Cuir / Leather



Tissu / Fabric

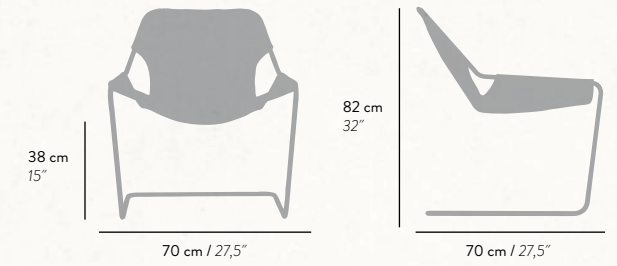
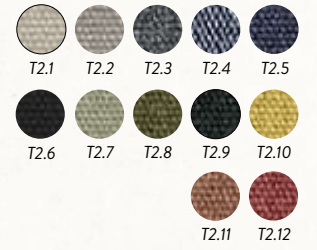

PAULISTANO Outdoor

p.30, 31, 102



- Barre acier carbone ø 19 mm - peinture extérieure haute durabilité
- Tissu 100% coton imputrescible, imperméable, anti-tâche

- Carbon steel - solid bar ø 0.75" - high durability outdoor powder coated
- Waterproof, rot proof and stain-proof 100% cotton canvas

Structure / Frame



Tissu / Fabric

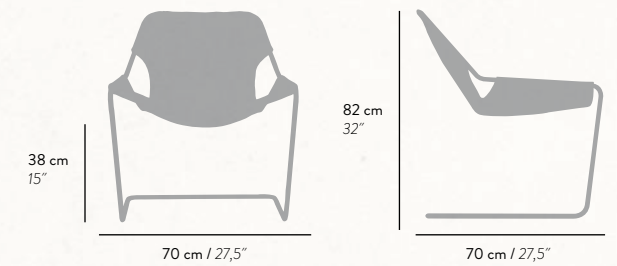
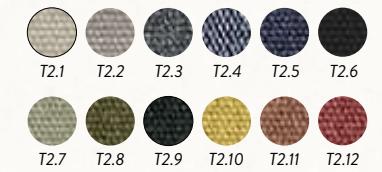

PAULISTANO Mesh

p.28, 29



- Barre acier inoxydable ø 19 mm
- Cotte de maille - anneaux ø 7 mm

- Stainless steel - solid bar ø 0.75"
- Mesh - 0.27" rings

Structure / Frame



Cotte de maille / Mesh

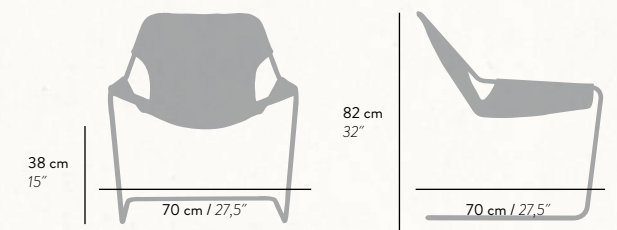

PAULISTANO Office Chair

p.34, 35, 36, 37



- Barre acier carbone phosphaté / acier inoxydable poli ø 19 mm
- Cuir pleine fleur - tannage végétal - semi-aniline

- Phosphated carbon steel / polished stainless steel - solid bar ø 0.75"
- Full grain leather - vegetable tanned - semi-aniline

Structure / Frame



Cuir / Leather

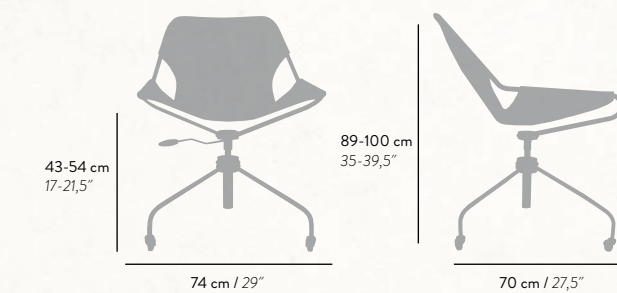

GAIVOTA

p.46, 47, 48, 49, 50

· Lamellé-collé de hêtre

· Beech plywood

Finition / Finish

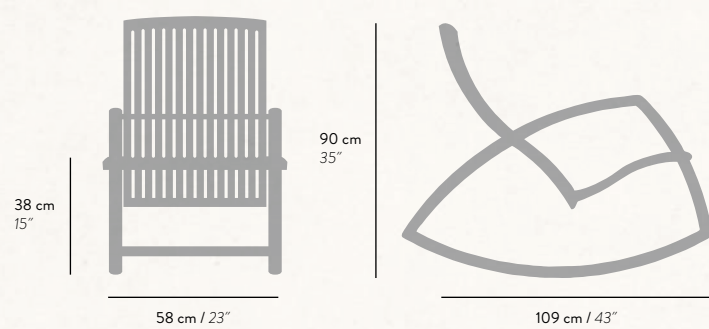

FDC1

p.66, 69, 74

· Barre acier carbone ø 14 mm - peinture époxy
· Cuir pleine fleur - tannage végétal - aniline

· Carbon steel - solid bar ø 0.55" - powder coated
· Full grain leather - vegetable tanned - aniline

Structure / Frame



Cuir / Leather

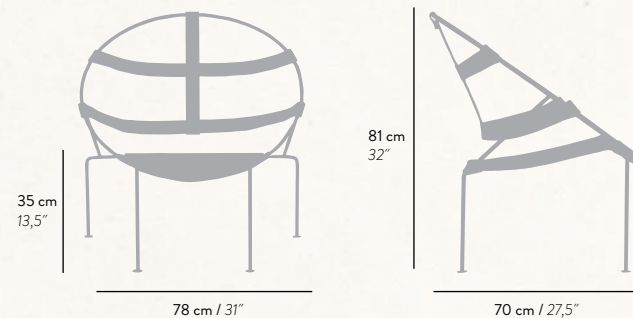

PEGLEV

Rocking-chair ou Fauteuil
/ Rocking chair or Armchair

p.40, 42, 43, 44, 45

· Chêne - noyer
· Cuir pleine fleur - tannage végétal
· semi-aniline

· Oak - walnut
· Full grain leather - vegetable tanned
· semi-aniline

Bois / Wood

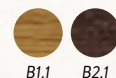

Cuir / Leather

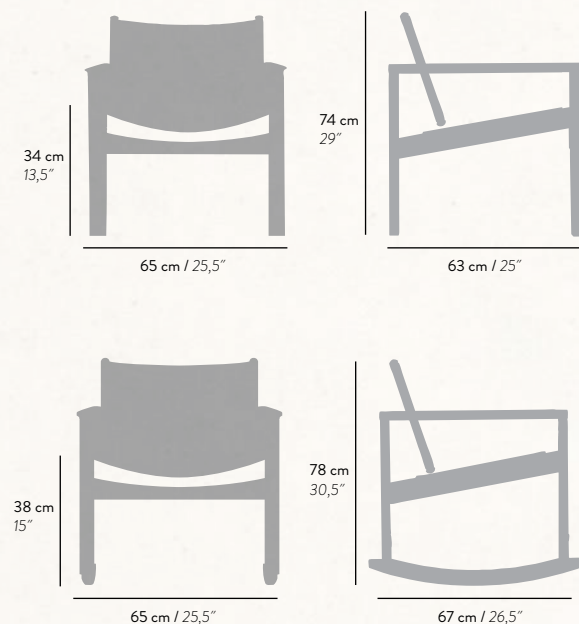

PMR

p.38, 39

· Barre acier ø 25 mm - feuille acier
épaisseur 4 mm - peinture époxy
· Cuir

Base / Base



Assise / Seat



· Steel - solid bar ø 1" - steel sheet -
thickness 0.15" - powder coated
· Leather

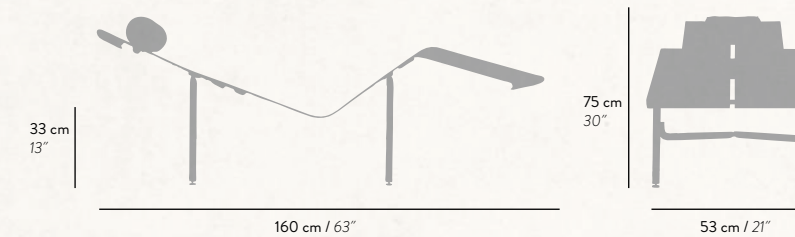

TRIBO

p.49, 62, 63, 65

· Barre acier carbone phosphaté - acier
inoxydable ø 16 mm
· Chêne

Structure / Frame



Bois / Wood



· Phosphated carbon steel -
polished stainless steel - solid bar ø 0.63"
· Oak

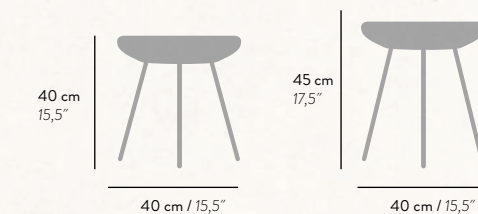

BIENAL

p.56, 57, 58, 60, 61

· Barre acier ø 12 mm peinture époxy
· Assise rembourrée cuir pleine fleur

Structure / Frame



Cuir / Leather

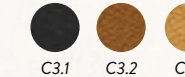

· Powder coated steel - solid bar ø 0.5"
· Padded full grain leather seat

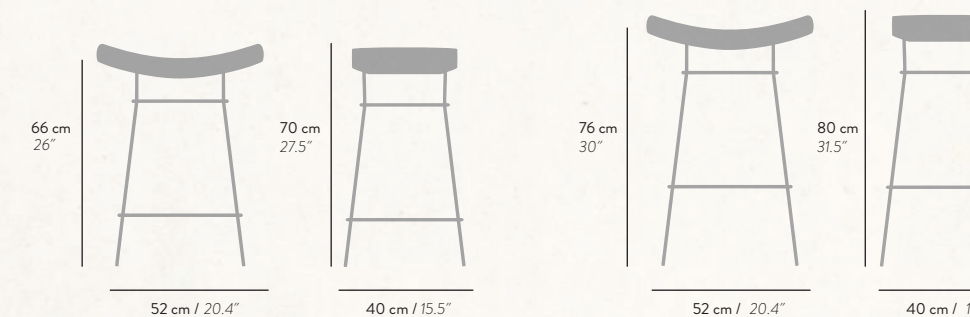

GABI

p.52, 53, 54, 55, 90

· Lamellé-collé de hêtre

· Beech plywood

Finition / Finish

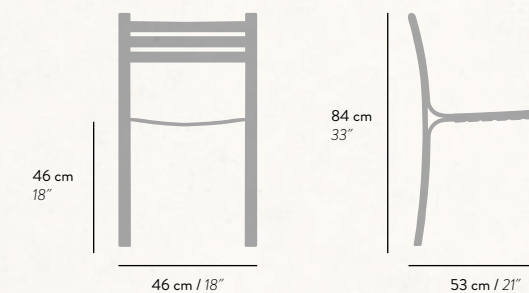

KAEKO

p.44, 84, 86, 87, 88

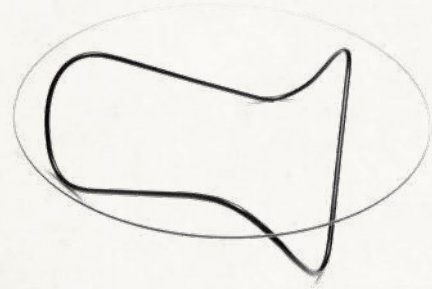

- Barre acier carbone peinture époxy - acier inoxydable poli ø 16 mm
- Verre trempé épaisseur 10 mm

- Powder coated carbon steel - polished stainless steel - solid bar ø 0.63"
- Tempered glass - thickness 0.40"

Base / Base



33 cm
13"

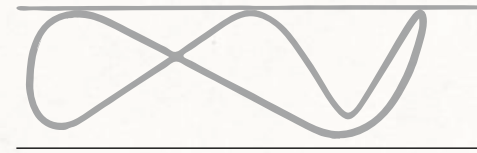

110 cm / 43"

MOEBIUS

p.90, 92, 94, 95



- Hêtre teinté noyer
- Verre trempé épaisseur 12 mm

- Walnut stained beechwood
- Tempered glass - 0.47" thickness

Finition / Finish



51 cm
20"

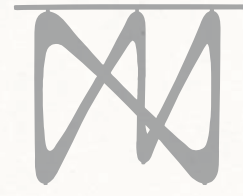

70 cm / 27,5"

TIPI

p.76, 78, 79, 80, 82, 83



- Acier peinture époxy
- Bois massif ou marbre de carrare

- Powder coated steel
- Solid wood or carrara marble

Structure / Frame



Plateau / Table top

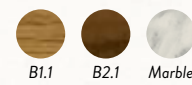

49 cm
19,5"

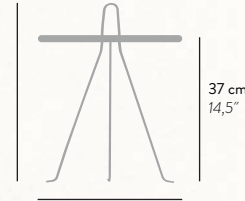

37 cm
14,5"

42 cm / 16,5"

62 cm
24,5"

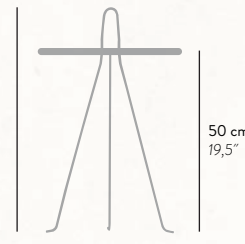

50 cm
19,5"

42 cm / 16,5"

MOÇA

p. 71, 72, 73, 74

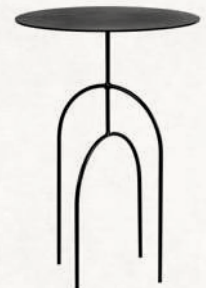

- Acier peinture époxy

- Powder coated steel

Structure / Frame



58 cm
23"

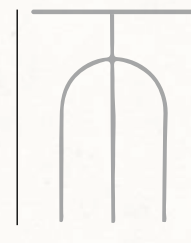

40 cm / 15,5"

48 cm
19"

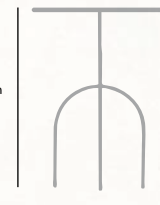

33 cm / 13"

QUATTRO CANTONI

p.97, 98, 99, 100



- Marbre bianco fiorito poli ou brossé mat
- Acier peinture époxy

- Polished or Matt brushed bianco fiorito marble
- Powder coated steel

Structure / Frame



Plateau / Table top



Brushed
Marble

Polished
Marble

33 cm
13"

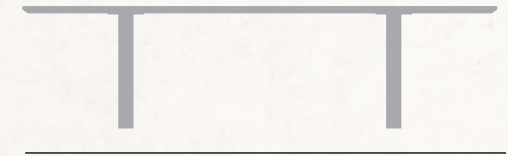

130 cm / 51"

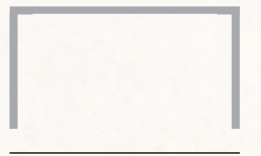

60 cm / 23,5"

ECLIPSE

p.6, 7, 8, 9, 11, 12, 13, 14, 27, 61, 80, 97

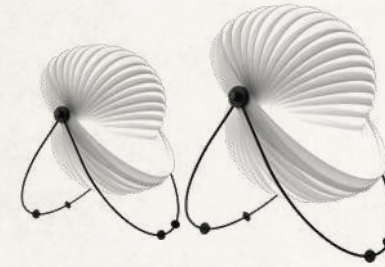

- Polyéthylène - polypropylène - acier
- 220V - ampoule standard type E27 - puissance max. 60w
- Conforme aux normes CE

- Polyethylene - polypropylene - steel
- 220v - standard bulb E27 - max power 60w
- In compliance with EC standards

36 cm
14"

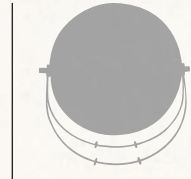

32 cm / 12,5"

52 cm
20,5"

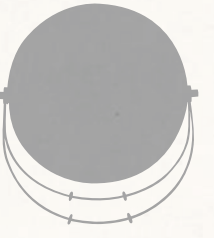

46 cm / 18"

PHOTO

p.102, 103



- Tissu - papier - styrene - pvc - acier
- (kit électrique de suspension non fourni)

- Fabric - paper - styrene - pvc - steel
- (electrical pendant kit not included)

Finition / Finish



25 cm
10"

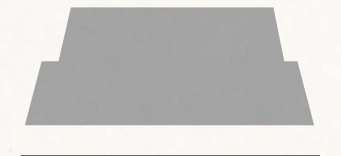

65 cm / 25,5"



